

ROEQ TLR750 EU

Pallet Lift 'n' Roll solution for the MiR600 & MiR1350



The ROEQ Lift 'n' Roll provides a unique dual-functionality solution, enabling efficient pallet handling between pick up & drop-off stations, such as pallet racks and conveyor stations. One of the key advantages is that it interacts directly with conveyor stations – eliminating the need for split conveyors, optimizing valuable factory floor space and simplifying the installation process.



Specifications

Robot compatibility:
MiR600, MiR1350

ROEQ product compatibility:
PR750 EU, Multi Rack EU,
GuardCom system

Payload:
440 kg / 970 lbs (MiR600)
750kg / 1650 lbs (MiR1350)

Stroke:
70 mm

Features

Optimized and Cost-Effective Solution:

- Dual Functionality – Integrates both lifter and roller, streamlining operations
- Design – Combines flexibility and cost efficiency in a single system
- Pallet Handling Efficiency – Seamlessly transfers pallets between racks and conveyors
- Space Optimization – Eliminates the need for split conveyors, - space saving and optimizing facility layout
- Increased Productivity – The AMR can operate with the lifter in the raised position, - minimizing cycle times and furthermore offers the ability to transport carts





Safety and Reliability:

- Advanced Cargo Monitoring – Cargo sensors track loads throughout the loading and unloading process and throughout AMR navigation
- Proven Reliability – Tested for consistent and dependable performance
- Streamlined Deployment – The ROEQ Assist software ensures quick and seamless system integration

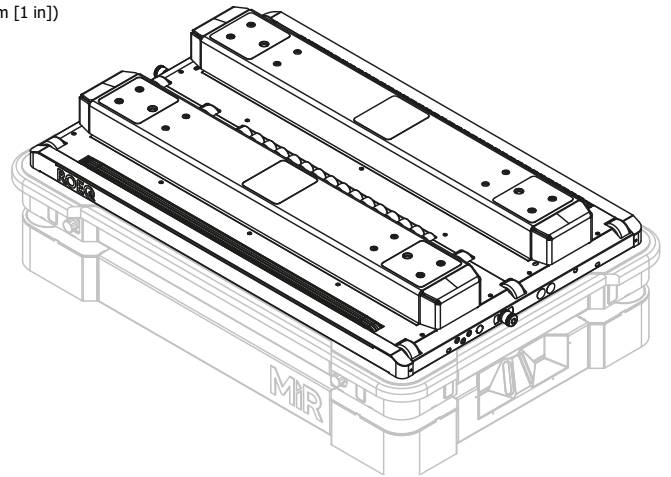
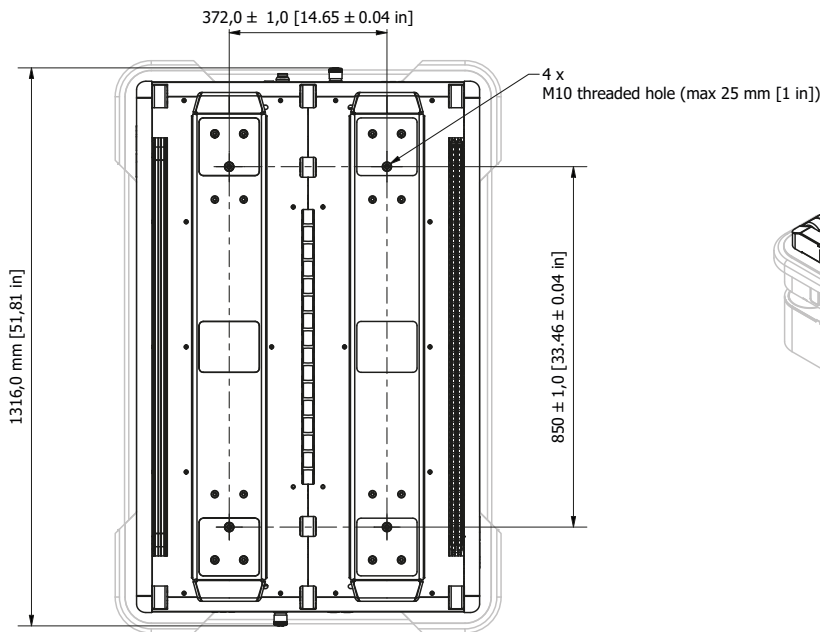
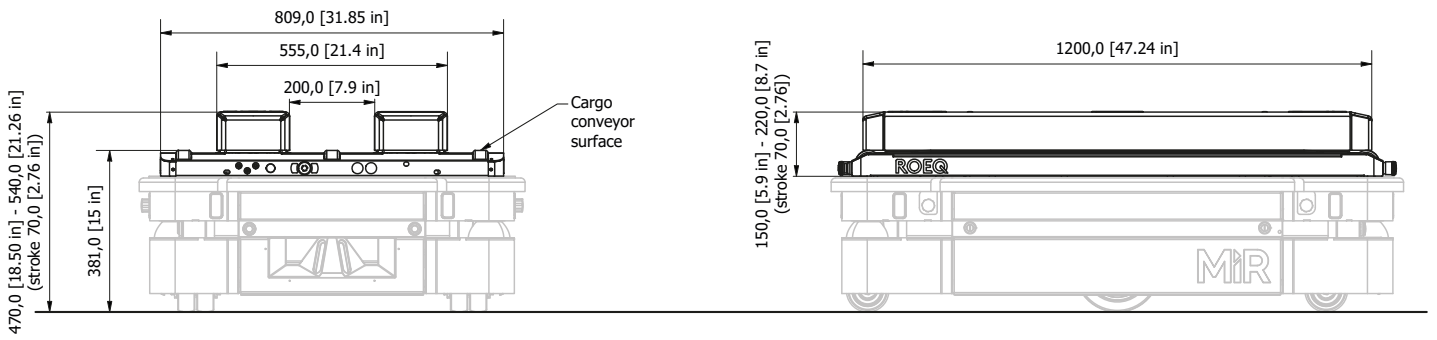
Comprehensive Turnkey Solution:

- Complete Accessory Offering – Includes ROEQ Pallet Racks, Multi Racks, and ROEQ GuardCom for end-to-end functionality



| Product name | Description | |
|---------------|---|---|
| TLR750 EU | Top Module for lifting Euro pallets on the MiR600 and MiR1350 |  |
| PR750 EU | Pallet Rack for pick up / drop off of EU Pallets. Payload 750kg. |  |
| Multi Rack EU | Space saving add-on to the PR750 EU for placing pallet racks in a row - saving approx. 250mm (10") per pallet |  |
| GuardCom | GuardCom unit to mount on stationary conveyor, for safe transfer of goods |  |
| GuardCom Link | Communications unit to mount on top rollers. Wireless communication with GuardCom, not using Wi-Fi |  |

Visit roeq.dk for more information or to see films of products in action.

Contact your local ROEQ Partner for more guidance